

# Turntide Smart Motor System™: V03 (10 HP)

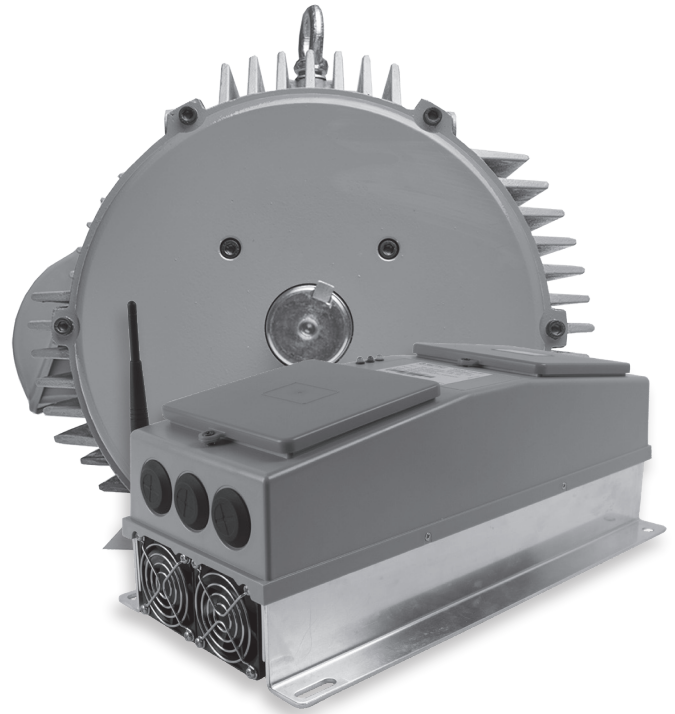

The Turntide Smart Motor System delivers unprecedented energy efficiency in a highly reliable switched reluctance design. This software-driven motor solution includes a Smart Motor and Motor Controller, complete with networking and connection capabilities to the cloud. The patented Turntide Motor System is proven to significantly reduce energy consumption, dramatically reducing energy costs and carbon footprint resulting from electric motor operation.

The V03 motor is suitable for a range of new and retrofit HVAC, refrigeration, and pumping applications in both fixed and variable speed.

## Turntide Smart Motor System

FEATURES	SMART MOTOR SYSTEM BENEFITS
Turntide Cascade® - PC graphic-based programming tool, part of the Turntide Controls Platform	Provides for customization to assure your motor control sequences can be accomplished for every application.
Configurable sequence of operation based on internal and external sensor feedback using up to 16 integrated I/O points	Reduces hardware needed to control HVAC and other equipment, reducing overall cost of system implementation.
Turntide Cloud	Provides monitoring and remote reporting, enabling extended data logging and alerts and alarms based on selectable parameters, protecting equipment and assuring the most efficient operation.
Built-in soft start and brownout protection	Eliminates nuisance service calls and interruptions to building operation due to inadvertent circuit breaker trips, reducing maintenance costs.





## System Efficiency vs Torque at Various Speeds

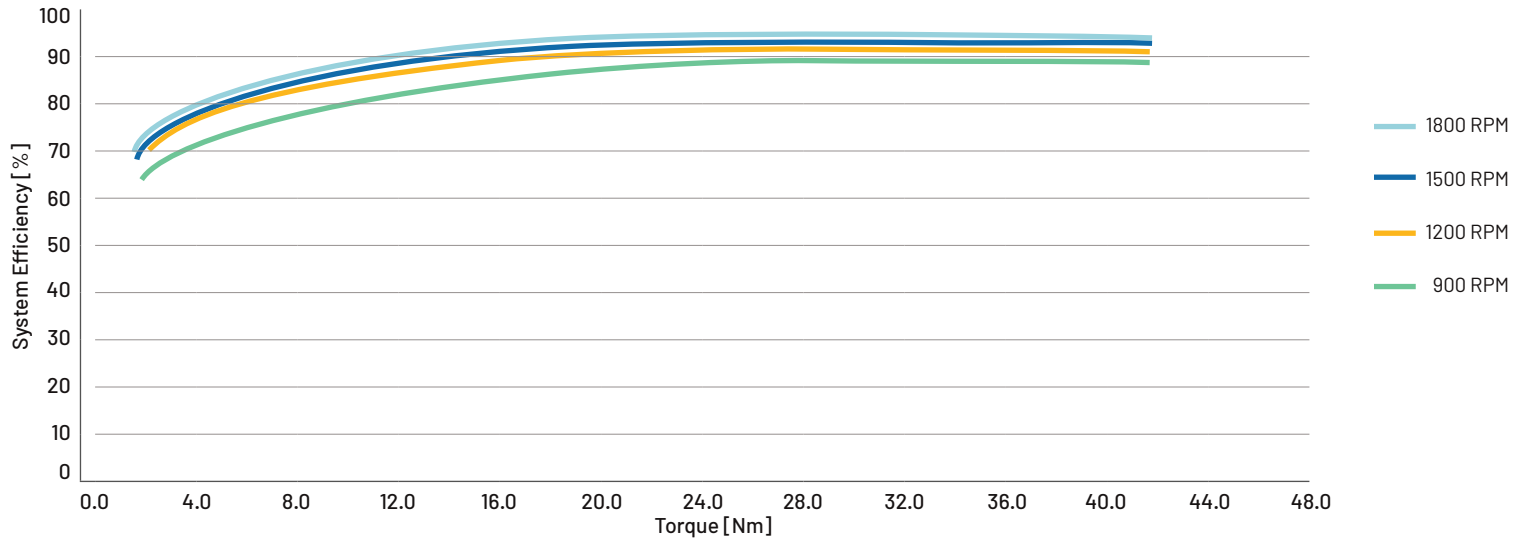

## Torque-Speed Curve

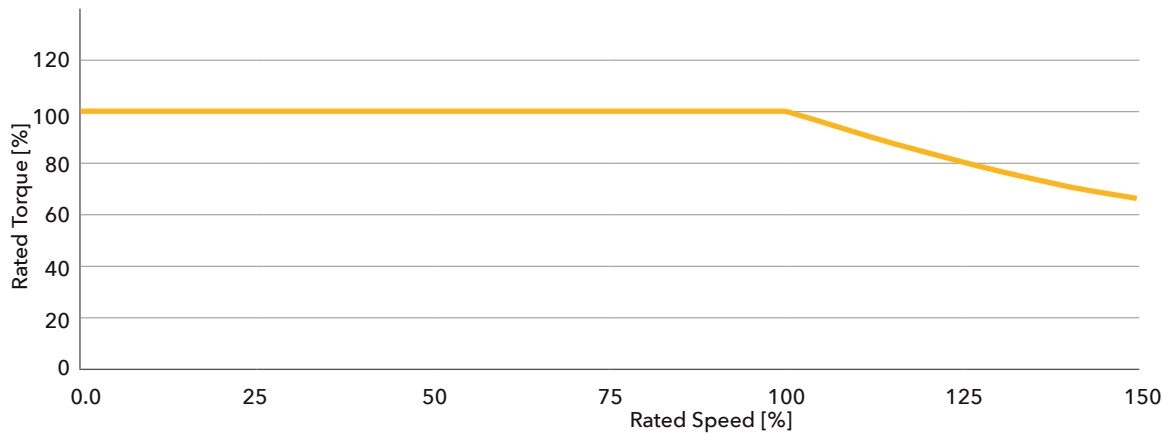

## Motor System Characteristics

Rated HP	10 HP	Motor Enclosure	TEFC
Rated RPM	1800 RPM	Duty Rating	Continuous
Operating RPM	100-3600 RPM	Rated Service Factor	1.15
Supply Voltage	460VAC	Motor to Controller Power Wire	10 AWG
Supply Phase	Three-Phase	Insulation Class	F
Supply Frequency	60Hz	Ambient Temperature Range	-10°C to +40°C
Peak System Efficiency	93%	Relative Humidity	95%, non-condensing
Power Factor over Operating Range	0.51-0.75	Rotor Inertia	0.100 lb-ft <sup>2</sup>
Motor Frame Sizes	213T/215T	Motor Weight	151 lb



# Motor Dimensions

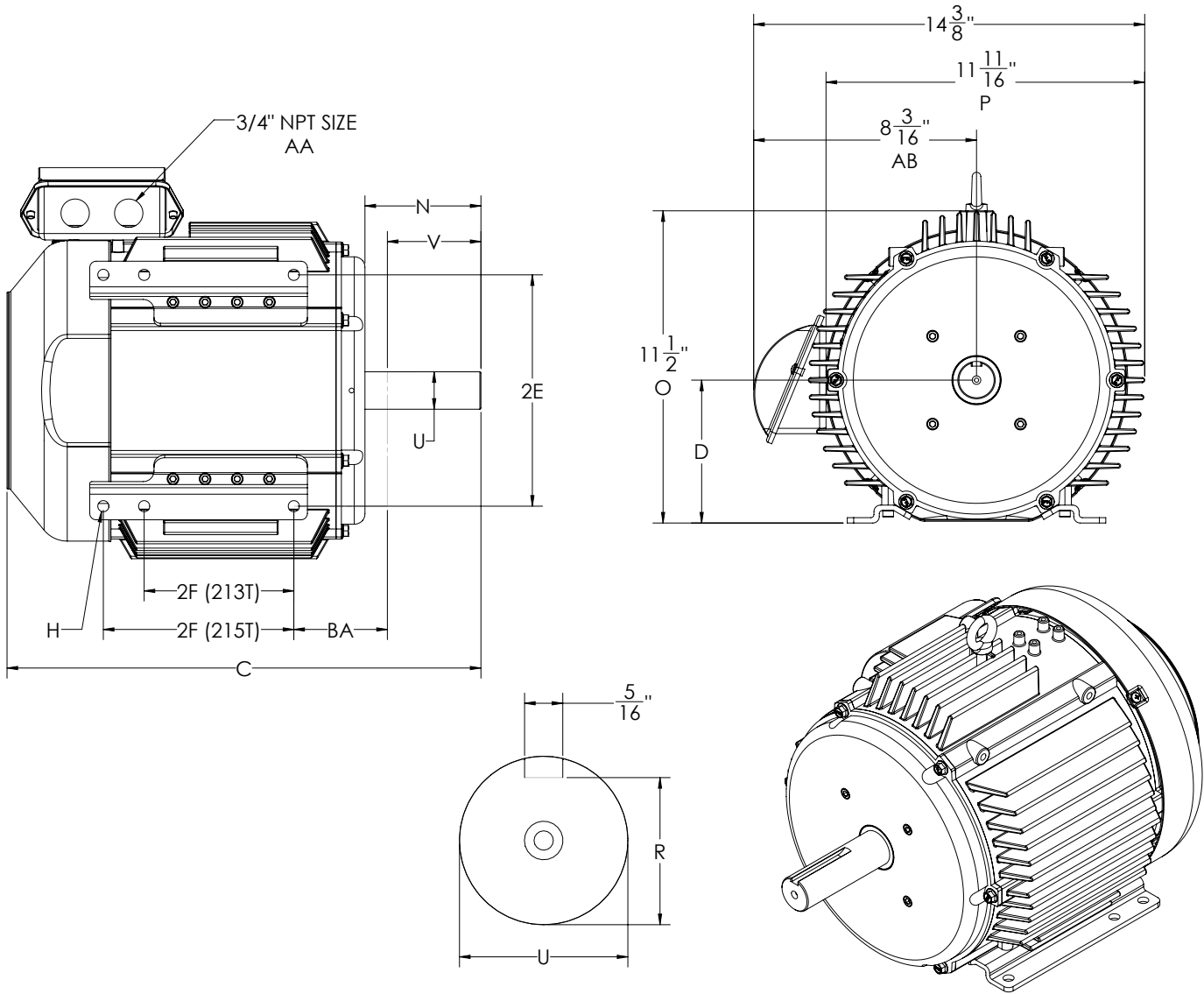

## Dimension Table (in inches)

NEMA	D	E	2F	H	U	V	BA	C
213T	5 ¼	4 ¼	5 ½	13/32	1 ¾	3 ¾	3 ½	17 ⅙
215T			7					

**Definitions:**

- D - height of shaft
- E - 1/2 distance between foot holes side-to-side
- 2F - distance between foot holes front to back
- H - foot hole size

- U - shaft diameter
- V - shaft length
- BA - distance from front foot hole to back of shaft horizontally
- C - Overall length

## Motor Mounting

Securely install motor with 3/8 inch bolts to a firm, rigid mounting surface with minimum vibration to establish good alignment with the driven load and the motor shaft. Proper alignment of the coupling mechanism with the motor shaft is critical to minimize vibration and maximize equipment life.



## Motor Controller Dimensions

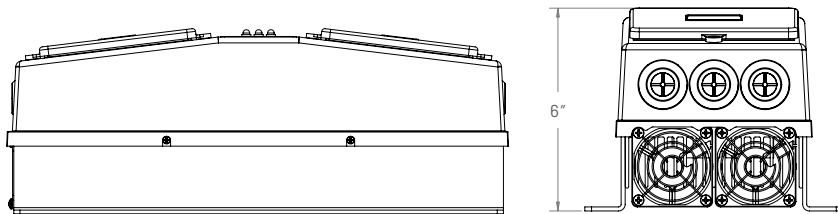
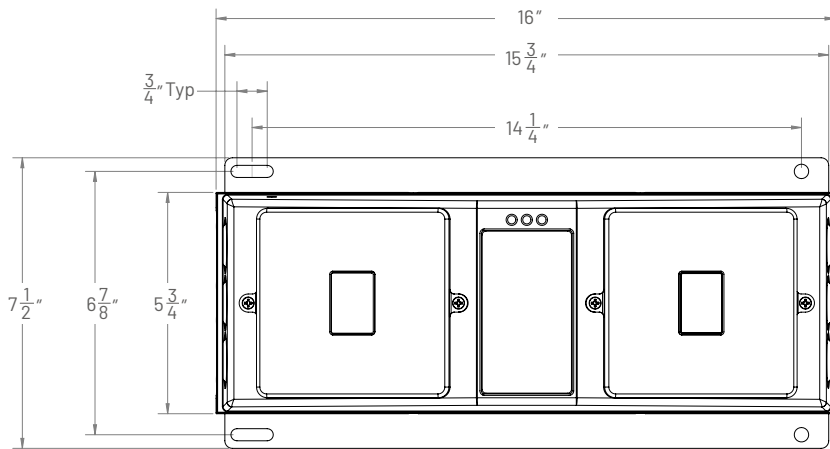

## Motor Controller I/O

QTY	Description
7	Programmable digital inputs
1	Programmable voltage output: 0-10, 20mA limit
4	Relay outputs: 1A, 125VAC limit
4	Universal inputs, individually selectable as: <ul style="list-style-type: none"> <li>Voltage Mode: 0-10V</li> <li>Current Mode: 0-20mA; or 4-20mA</li> <li>Resistive Mode</li> <li>External Logic Mode</li> </ul>

## Turntide Motor Controller

The Turntide Motor Controller controls all operations of the Turntide Smart Motor and is required for motor operation. Its internal program assures that the motor is operating at the highest efficiency at any speed in any application. It does this by monitoring the internal sensors and feedback from the Smart motor and adjusting control signals for optimization. The Motor Controller provides physical connection for 13 sensors and relay output connections for control and monitoring of associated equipment such as RTUs, AHUs and pumps. The Motor Controller can be configured with Cascade software to operate under an infinite number of control scenarios. When connected with the Turntide Supervisor, remote configuration, updates, alerts, alarms, and system data logging can be delivered through Turntide Cloud or a BMS system.

### TURNTIDE TECHNOLOGY FOR SUSTAINABLE OPERATIONS

Our breakthrough technologies accelerate electrification and sustainable operations for energy-intensive industries.

