

Turttide Gen4- HVLP10/20 Inverters

A range of high voltage, low power AC motor inverters designed primarily for the control of pumps and fans on hybrid and electric buses, agricultural implements, tractors and other high voltage vehicles. There are two models in the range, which cover both liquid cooled and air cooled designs. A compact, rugged and cost effective design, Turttide's HVLP Inverter range is well suited for OEMs, hybrid/ electric bus & truck conversions, Agricultural OEMs and EV system integrators. The high voltage range is fully operational from 150V up to 800VDC.

Benefits

The high voltage, but low power design is perfect for operating hotel / auxilliary loads, such as pumps and fans, on a wide range on On and Off-highway vehicles.

Quality and reliability - Our products are used by some of the worlds leading automotive and industrial companies in several innovative and demanding applications. The same quality and reliability is designed into each and every Turttide product.

Specifications

	Gen4- HVLP20	Gen4- HVLP10
Voltage and current range		
100% Derating (VDC)	800VDC	
Nominal (VDC)	700VDC	
Min Battery Voltage (V)	128V	
Peak current (2 min)(A_{rms})	53A _{rms} (1min)	24A _{rms} (1min)*
Continuous (60 min)(A_{rms})	33A _{rms}	19A _{rms} *
Control Method	Master and Slave functionality options No electrical isolation of CAN port	
Communications	CAN 2.0B	



Gen4- HVLP10



Gen4- HVLP20

Features

- Supports AC Permanent Magnet synchronous motor and AC Induction motors
- Highly efficient advanced flux vector motor control
- Up to 800VDC peak supply voltage
- Up to 53A_{rms} peak power output
- Up to 33A_{rms} continuous power output
- Includes an additional dedicated safety I/O circuit
- 12V or 24V supply
- Range of encoders supported including resolver

*Rating based on static air. Higher rating can be achieved with forced air cooling

Communications protocol	CANOpen H-Protocol (J1939)	Encoders	Absolute UVW encoder input Absolute Sin/Cos encoder input Incremental AB encoder input Resolver automatic gain
I/O	All I/O protected to 40V operation with 12V or 24V 4 analogue inputs 0-10V 4 digital inputs 2 power supplies 5V-10V (100mA and 200mA) 2 digital outputs	Electrical Safety	IEC60664 UL840 ISO6469

	Turntide Liquid-Cooled Inverter (700V, 53A)	Turntide Air-Cooled Inverter (700V, 24A)
Environmental		
IP rating	IP6k9k	
Temperature	Ambient temperature -40°C to +45°C Automatic derating above 45°C	
Flow Rate	6l/min	Not Applicable
Coolant temperature	-40°C to +85°C (with 60:40 Glycol Water mix) Automatic derating above 70°C	Not Applicable
Configuration	Turntide offer a Windows-based PC tool for configuration of the inverter. The tool provides a simple yet powerful means of accessing the CANOpen bus for diagnostics or parameter adjustment. Communication is through CAN, an IXXAT CAN-to-USB dongle is required.	
Dimensions (all dimensions in millimeters)		
Weight	2.3kg dry	3.7kg

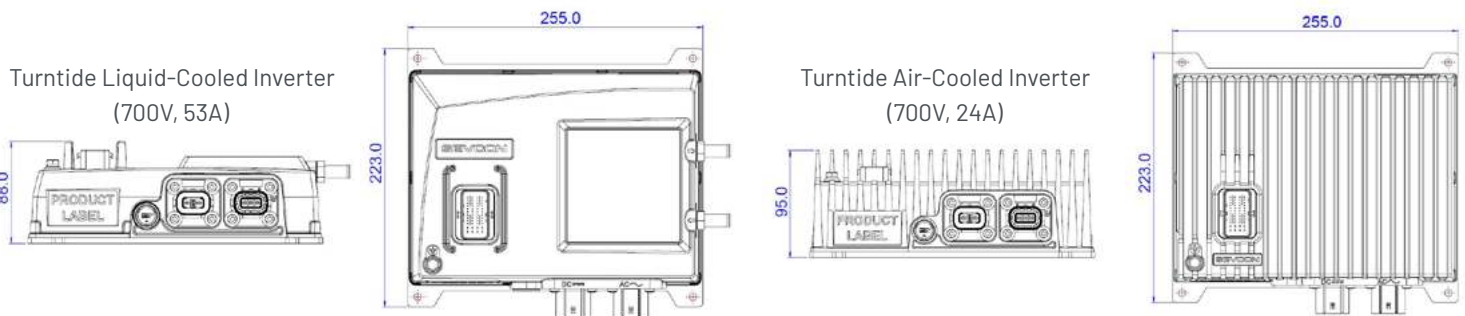

For further information please contact our team of experts at electrificationsales@turntide.com

TURNTIDE TECHNOLOGIES

Our breakthrough technologies accelerate electrification and sustainable operations for energy-intensive industries

Turntide Technologies | 1295 Forgewood Avenue, Sunnyvale, CA 94089
turntide.com | electrificationsales@turntide.com